

400mA Single-Cell Lithium Battery Charger IC

CN3142

General Description:

The CN3142 is a complete constant-current /constant voltage linear charger for single cell Li-ion and Li Polymer batteries. The device contains an on-chip power MOSFET and eliminates the need for the external sense resistor and blocking diode. An on-chip adaptive cell can adjust charging current automatically based on the output capability of input power supply, so CN3142 is ideally suited for solar powered system. Thermal feedback regulates the charge current to limit the die temperature at about 132°C during high power operation or high ambient temperature. The regulation voltage is internally fixed at 4.2V with 1% accuracy. The charge current can be set externally with a single resistor, the minimum charge current can be set down to 3mA, which makes CN3142 very suitable for charging ultra-small capacity battery. When the input supply is removed, the CN3142 automatically enters a low power sleep mode, dropping the battery drain current to less than 3µA.

Other features include undervoltage lockout, automatic recharge, JEITA-compliant battery temperature monitoring, over charge current protection and charging indicator.

The CN3142 is available in 6-pin SOT23 package.

Features:

- Input Supply Voltage Range: 4.5V to 6V
- Automatic charge current adjustment based on the output capability of input power supply
- Suitable for Solar-Powered System
- Regulation voltage: 4.2V ± 1%
- Continuous Charge Current Up to 400mA
- Minimum Constant Charge Current down to 3mA
- Over Charge Current Protection in case Short Circuit at ISET Pin
- Precharge Conditioning for Reviving Deeply Discharged Cells and Minimizing Heat Dissipation During Initial Stage of Charge
- Constant-Current/Constant-Voltage Operation with Thermal Regulation to Maximize Charge Rate Without Risk of Overheating
- Automatic Low-Power Sleep Mode When Input Supply Voltage is Removed
- Status Indication for LEDs or uP Interface
- Automatic Charge Termination and Recharge
- JEITA-Compliant Battery Temperature Monitoring
- Available in SOT23-6 Package
- Pb-free, rohs-Compliant and Halogen Free

Applications:

- Medical Electronics
- Beauty and Grooming
- Fleet Management, Asset Tracking
- Solar Powered System
- Portable Devices

Pin Assignment

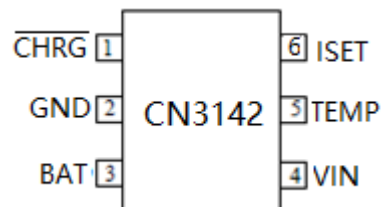

CONSONANCE

Typical Application Circuit

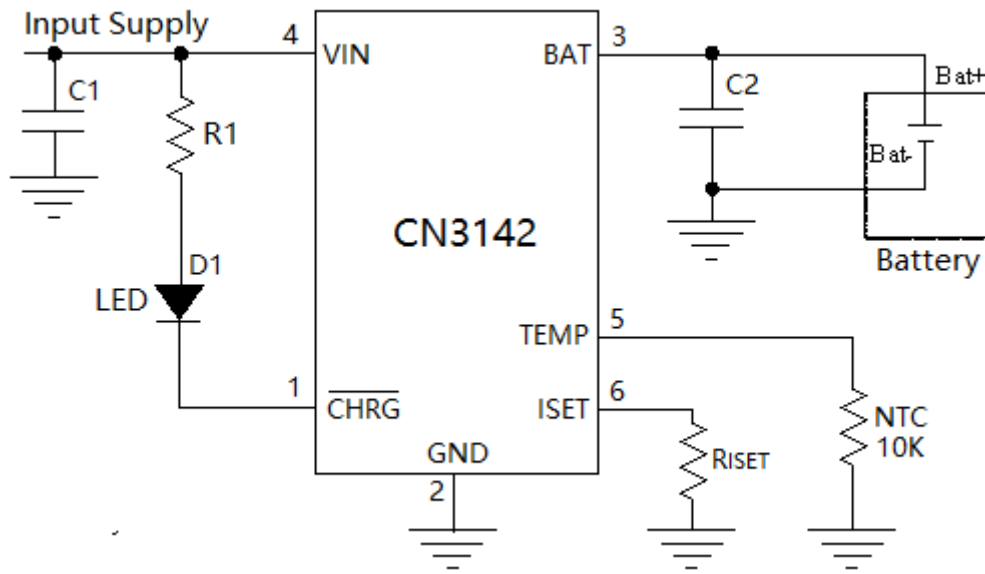

Figure 1 Typical Application Circuit

Ordering Information:

Part No.	Package	Top Marking	Shipping	Operating Temperature Range
CN3142	SOT23-6	3142	Tape&Reel, 3K/Reel	-40°C to +85°C

CONSONANCE

Block Diagram

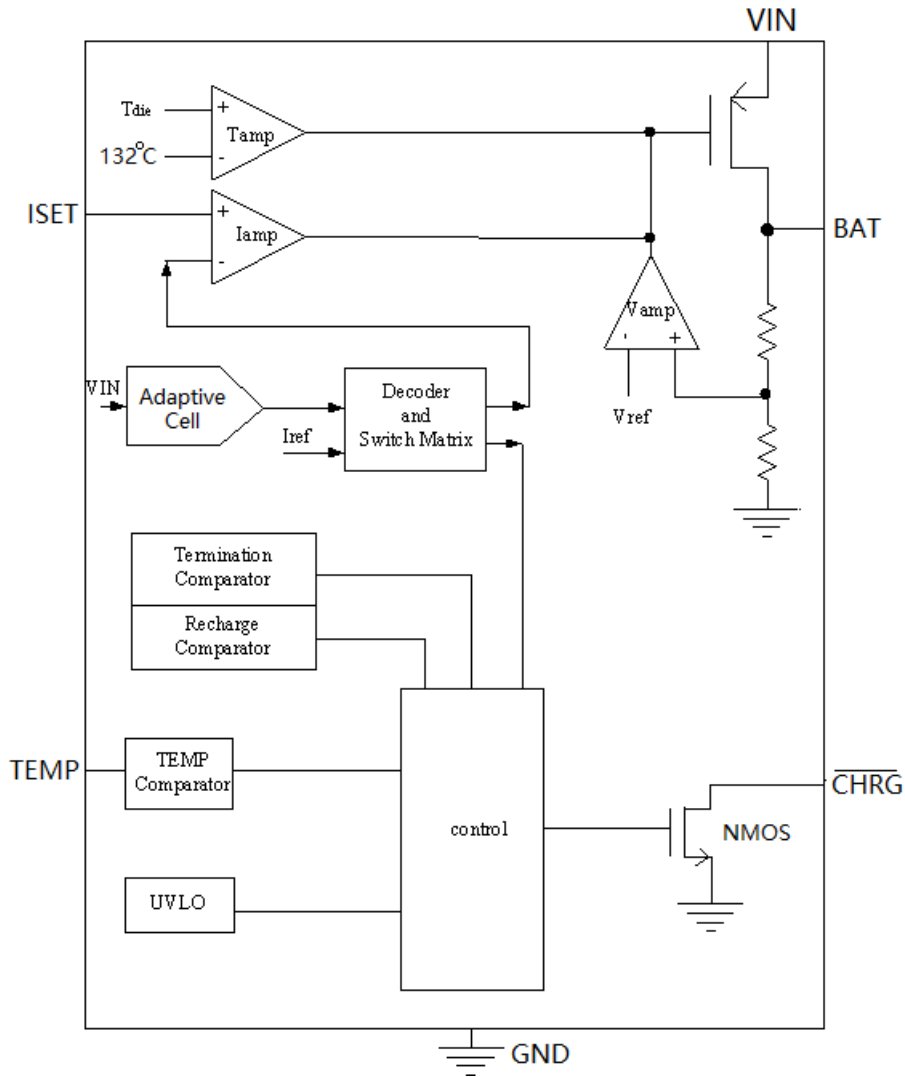

Figure 2 Block Diagram

CONSONANCE

Pin Description

Pin No.	Name	Function Description
1	$\overline{\text{CHRG}}$	Open Drain Charge Status Output. When the battery is being charged, the $\overline{\text{CHRG}}$ pin outputs pulse of 2Hz frequency, the LED connected to $\overline{\text{CHRG}}$ pin will blink. In termination mode, $\overline{\text{CHRG}}$ pin is pulled low by an internal switch. In other cases $\overline{\text{CHRG}}$ pin is in high impedance state.
2	GND	Ground Terminal (Ground).
3	BAT	Battery Positive Terminal Connection Pin. Connect the positive terminal of the battery to BAT pin. BAT pin draws less than 3uA current in sleep mode. BAT pin provides charge current to the battery and provides regulation voltage.
4	VIN	Positive Input Supply Voltage. VIN is the power supply to the internal circuit. When VIN drops to within 10mv of the BAT pin voltage, CN3142 enters low power sleep mode, dropping BAT pin's current to less than 3uA.
5	TEMP	<p>Battery Temperature Monitoring Input. Connecting a 10K ohm NTC thermistor between TEMP pin and GND.</p> <ul style="list-style-type: none"> ● If TEMP pin's voltage is below 0.1V or above 0.85V, which means battery is too hot or too cold, charging is suspended. ● If TEMP's voltage is between 0.1V and 0.135V, which means battery is warm, charge current is reduced to 50% of full-scale current set by resistor at ISET pin and regulation voltage is reduced to 4.085V. ● If TEMP's voltage is between 0.135V and 0.55V, CN3142 functions normally. ● If TEMP's voltage is between 0.55V and 0.85V, which means battery is cool, charge current is reduced to 25% of full-scale current set by resistor at ISET pin. <p>If battery temperature monitoring function is not needed, connect a fixed 10K ohm resistor from TEMP pin to GND.</p>
6	ISET	<p>Constant Charge Current Setting and Charge Current Monitor Pin. The charge current is set by connecting a resistor R_{ISET} from this pin to GND. When in precharge mode, the ISET pin's voltage is regulated to 0.4V. When in constant charge current mode, the ISET pin's voltage is regulated to 1.205V. In all modes during charging, the voltage on ISET pin can be used to measure the charge current as follows:</p> $I_{\text{CH}} = (V_{\text{ISET}} / R_{\text{ISET}}) \times 417$

Absolute Maximum Ratings

All Terminal Voltage..... -0.3V to 6.5V
 BAT Short-Circuit Duration.....Continuous
 Storage Temperature..... -65°C to 150°C
 Lead Temperature(Soldering, 10s).....260°C

Maximum Junction Temperature.....150°C
 Operating Temperature..... -40°C to 85°C
 Thermal Resistance (SOT23-6).....TBD

Stresses beyond those listed under 'Absolute Maximum Ratings' may cause permanent damage to the device. These are stress ratings only and functional operation of the device at these or any other conditions above those indicated in the operational sections of the specifications is not implied. Exposure to Absolute Maximum Rating Conditions for extended periods may affect device reliability.

CONSONANCE

Electrical Characteristics

(VIN=5V, TA=−40°C to 85°C, Typical Values are measured at TA=25°C, unless otherwise noted)

Parameters	Symbol	Test Conditions	Min	Typ	Max	Unit
Input Supply Voltage	VIN		4.5		6	V
Operating Current	IVIN	Charge Termination Mode	280	390	500	uA
Undervoltage Lockout	Vuvlo	VIN falling		2.4	2.65	V
Undervoltage Lockout Hysteresis	Huvlo			0.12		V
Soft Start Time	tss		100	160	220	uS
Regulation Voltage	VREG	Constant Voltage Mode	4.158	4.2	4.242	V
BAT pin Current	ICC1	RISSET=1.25K, VBAT=3.6V	340	400	460	mA
	IPRE1	RISSET=1.25K, VBAT=2.4V	101	133	165	
	ISRT1	RISSET=1.25K, VBAT=0V	30	44	60	
	ISDBY	VBAT=4.2V, termination mode	1.8	3.7	7	uA
	ISLP	VIN=0V, sleep mode			3	
Battery Short-circuit						
Short-circuit Threshold	VSRT	Battery voltage falls	0.58	0.89	1.2	V
Short-circuit Current	ISRT	VBAT < VSRT	6	11	16	%ICC
Precharge (Trickle Charge)						
Precharge Threshold	VPRE	Voltage at BAT pin rising	2.67	2.8	2.93	V
Precharge Threshold Hysteresis	HPRE			68		mV
Precharge Current	IPRE	VSRT < VBAT < VPRE	25	33.3	42	%ICC
Charge Termination Threshold						
Charge Termination Threshold	Iterm	Charge current falls	6	11.2	16	%ICC
Recharge Threshold						
Recharge Threshold	IRECH	Charge current rises	25	33.3	42	%ICC
	VRECH	Battery voltage falls	4.02	4.085	4.15	V
Sleep Mode						
Sleep Mode Threshold	VSLP	VIN from high to low, measures the voltage (VIN − VBAT)		10		mV
Sleep mode Release Threshold	VSLPR	VIN from low to high, measures the voltage (VIN − VBAT)		60		mV
Over Charge Current Protection						
Over Charge Current Threshold	IOCP		0.39	0.47	0.6	A
Deglitch Time	tOCP_DGL	Deglitch time for over charge current protection	1.2	2	2.7	ms
ISET Pin						
ISET Pin Voltage	VISET	Precharge mode	0.32	0.4	0.48	V
		Constant current mode	1.12	1.205	1.29	

CONSONANCE

Electrical Characteristics (Continued from last page)

Parameters	Symbol	Test Conditions	Min	Typ	Max	Unit
TEMP Pin						
TEMP Source Current	I_{TEMP}		27	30	33	uA
Cold Threshold	V_{COLD}	V_{TEMP} rises, cool to cold	800	850	900	mV
Cold Release Threshold	V_{COLDR}	V_{TEMP} falls, cold to cool	755	805	855	mV
Cool Threshold	V_{COOL}	V_{TEMP} rises, normal to cool	510	550	590	mV
Cool Release Threshold	V_{COOLR}	V_{TEMP} falls, cool to normal	465	505	545	mV
Warm Threshold	V_{WARM}	V_{TEMP} falls, normal to warm	120	135	150	mV
Warm Release Threshold	V_{WARMR}	V_{TEMP} rises, warm to normal	138	155	172	mV
Hot Threshold	V_{HOT}	V_{TEMP} falls, warm to hot	85	100	115	mV
Hot Release Threshold	V_{HOTR}	V_{TEMP} rises, hot to warm	105	120	135	mV
\overline{CHRG} Pin						
\overline{CHRG} Sink Current	I_{CHRG}	$V_{CHRG}=0.3V$, Termination mode	10			mA
\overline{CHRG} Leakage Current		$V_{CHRG}=6V$, Sleep mode	1			uA

Note: I_{CC} is the full-scale charge current set by the resistor at ISET pin.

Detailed Description

The CN3142 is a linear battery charger IC designed primarily for charging single cell lithium-ion or lithium-polymer battery. Featuring an internal P-channel power MOSFET, the charger uses a constant-current/constant-voltage to charge the battery. Continuous charge current can be set up to 400mA with an external resistor, and minimum charge current can be set down to 3mA, which makes CN3142 very suitable for ultra-small capacity battery. The on-chip adaptive cell can adjust charging current automatically based on the output capability of input power supply, so CN3142 is ideally suited for the solar-powered systems, or the applications that need to charge a battery with an input power supply whose output capability is limited. The open-drain output \overline{CHRG} indicates the charger's status. The internal thermal regulation circuit reduces the programmed charge current if the die temperature attempts to rise above a preset value of approximately 132°C. This feature protects the CN3142 from excessive temperature, and allows the user to push the limits of the power handling capability of a given circuit board without risk of damaging the CN3142 or the external components. Another benefit of adopting thermal regulation is that charge current can be set according to typical, not worst-case, ambient temperatures for a given application with the assurance that the charger will automatically reduce the current in worst-case conditions.

The charge cycle begins when the voltage at the VIN pin rises above 4.5V and above battery voltage, a current set resistor is connected from the ISET pin to ground. The \overline{CHRG} pin outputs a pulse of 2Hz frequency to indicate that the charge cycle is ongoing. At the beginning of the charge cycle, if the voltage at BAT pin is below 2.8V(Typical), the charger is in precharge mode to bring the cell voltage up to a safe level for charging. The charger goes into the fast charge constant-current mode once the voltage on BAT pin rises above 2.8V. In constant current mode, the charge current is set by R_{ISET} . When the battery approaches the regulation voltage of 4.2V, the charge current begins to decrease as the CN3142 enters the constant-voltage mode. When the current drops to charge termination threshold, \overline{CHRG} pin output low level to indicate that the charge cycle is terminated. The charge termination threshold is 11.2% of the current in constant current mode. To restart the charge cycle, just remove the input voltage and reapply it. The charge cycle can also be automatically restarted if the charge current rises above the recharge threshold. The on-chip reference voltage, error amplifier and the resistor divider provide regulation voltage with 1% accuracy which can meet the requirement of lithium-ion and lithium polymer

CONSONANCE

batteries. When the input voltage is not present, the charger goes into a sleep mode, dropping battery drain current to less than 3uA. This greatly reduces the current drain on the battery and increases the standby time. During charging, battery temperature is continuously monitored in cooperation with an NTC thermistor connected between TEMP pin and GND. The battery temperature monitoring function provided by CN3142 is designed to follow JEITA temperature standard for lithium batteries.

The charging profile is shown in the following figure:

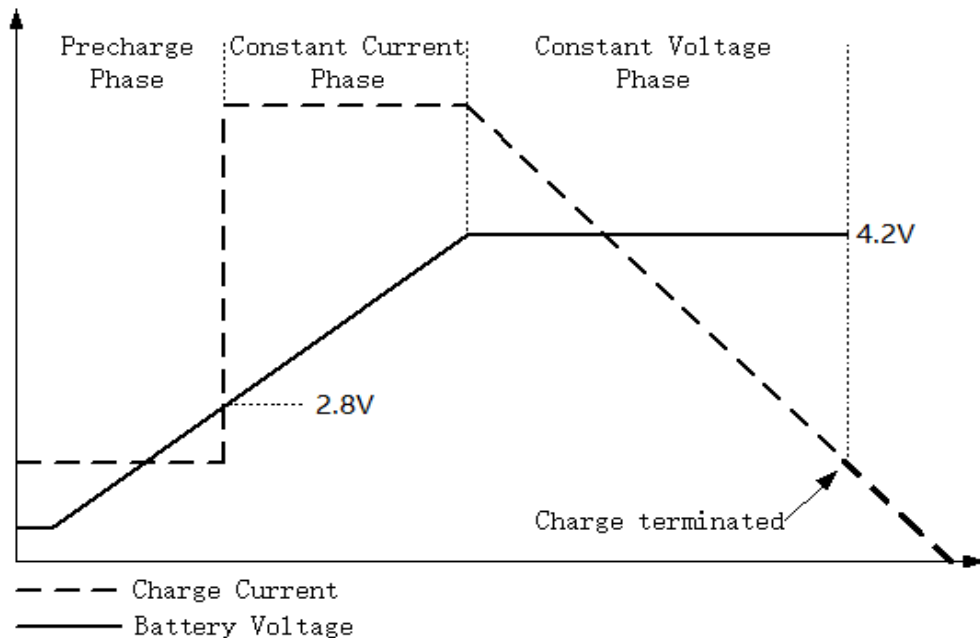

Figure 3 Charging Profile

Application Information

Undervoltage Lockout (UVLO)

An internal undervoltage lockout circuit monitors the input voltage and keeps the charger in shutdown mode until VIN rises above the undervoltage lockout voltage. The UVLO circuit has a built-in hysteresis of 0.12V.

Sleep mode

There is an on-chip sleep comparator. The comparator keeps the charger in sleep mode if VIN falls below sleep mode threshold ($V_{BAT}+10\text{mV}$). Once in sleep mode, the charger will not come out of sleep mode until VIN rises 60mV above the battery voltage.

Precharge mode

At the beginning of a charge cycle, if the battery voltage is below 2.8V(Typical), the charger goes into precharge mode or trickle charge mode, and the charge current is 33.3% of fast charge current in constant current mode.

Charging Current limited by the Output capability of Input Power Supply

If the output capability of input power supply is less than the charging current set by the resistor at ISET pin, then the on-chip adaptive cell will begin to function to adjust the charging current based on the output capability of input power supply. In this case, the actual charging current may be less than the value set by the resistor at ISET pin, but it is maximized to the output capability of input power supply on the condition that the input voltage at VIN pin is no less than 4.5V(Typical), which is the minimum operating voltage of CN3142. So the charging current can be set according to the maximum output capability of input power supply, not the worst case.

CONSONANCE

Setting Charge Current

The formula for the charge current in constant current mode is:

$$I_{CH} = 502V / R_{ISET}$$

Where:

I_{CH} is the charge current in ampere

R_{ISET} is the total resistance from the ISET pin to ground in ohm

For example, if 400mA charge current is required, calculate:

$$R_{ISET} = 502V / 0.4A = 1.25k\Omega$$

For best stability over temperature and time, 1% metal film resistors are recommended. If the charger is in constant-temperature or constant voltage mode, the charge current can be monitored by measuring the ISET pin voltage, and the charge current is calculated as the following equation:

$$I_{CH} = (V_{ISET} / R_{ISET}) \times 417$$

Combine Two Power Inputs

Although the CN3142 allows charging from a solar power supply, a wall adapter or a USB port can also be used to charge Li-Ion/Li-polymer batteries. Figure 4 shows an example of how to combine 2 power inputs. A P-channel MOSFET, M1, is used to prevent back conducting into the 2nd power supply when the 1st power supply is present and Schottky diode, D1, is used to prevent 2nd power supply loss through the 1k Ω pull-down resistor.

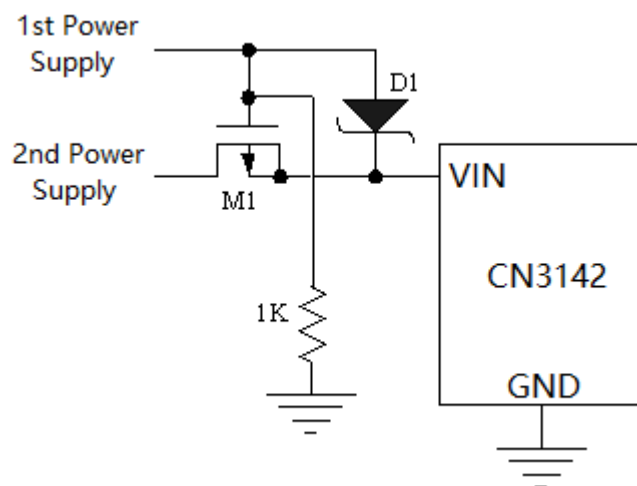

Figure 4 Combining 2 Input Power Supply

Battery Temperature Monitoring

To prevent the damage caused by the very high or very low temperature done to the battery, the CN3142 continuously monitors battery temperature by measuring the voltage at TEMP pin which is determined by TEMP pin's source current (30uA typical) and a negative temperature coefficient (NTC) thermistor connected between TEMP pin and GND as shown in Figure 1.

If battery temperature monitoring function is not needed, connect a fixed 10Kohm resistor from TEMP to GND.

The battery temperature monitoring function for CN3142 is designed to follow the JEITA temperature standard for Li-Ion and Li-Poly batteries; charge current and regulation voltage (V_{REG}) are reduced based on battery temperature ranges.

There are totally five battery temperature ranges for CN3142:

- Hot: Above 55°C,
- Warm: 45°C to 55°C,

CONSONANCE

- Normal: 10°C to 45°C
- Cool: 0°C to 10°C,
- Cold: Below 0°C.

Normal operation occurs when battery temperature is between 10°C and 45°C, charge current and voltage will be the normal values.

When battery is in the Cool temperature range, which is between 0°C and 10°C, the charge current is 25% of full-scale charge current and regulation voltage is not changed.

When the battery is in the Warm temperature range, which is between 45°C and 55°C, the charge current is reduced to 50% of full-scale charge current and regulation voltage is reduced to 4.085V from 4.2V.

Charging is suspended if battery temperature is below Cold temp of 0°C or above Hot temp of 55°C. When charging is suspended, $\overline{\text{CHRG}}$ pin becomes high impedance state.

Once battery temperature is not in hot range and cold range, charging resumes automatically.

TEMP pin voltage is the product of its source current and NTC's resistance, so the selection of NTC should make sure TEMP pin voltage meet the requirements of hot, warm, cool and cold threshold. An NTC of nominal resistance 10K ohm at room temperature may be suitable for CN3142.

A resistor of small resistance in series with NTC thermistor and a resistor of large resistance in parallel with NTC thermistor can fine tune CN3142's temperature range.

The following table lists TEMP pin voltage, charge current and regulation voltage in the above-mentioned 5 battery temperature range.

Battery Temperature Range	TEMP Pin Voltage	Charge Current	Regulation Voltage
Hot: above 55°C	$V_{\text{TEMP}} < V_{\text{HOT}}$	Charge Suspended	Charge Suspended
Warm: 45°C to 55°C	$V_{\text{HOTR}} < V_{\text{TEMP}} < V_{\text{WARM}}$	50% * I _{CC}	4.085V
Normal: 10°C to 45°C	$V_{\text{WARMR}} < V_{\text{TEMP}} < V_{\text{COOLR}}$	Normal Value	4.2V
Cool: 0°C to 10°C	$V_{\text{COOL}} < V_{\text{TEMP}} < V_{\text{COLDR}}$	25% * I _{CC}	4.2V
Cold: below 0°C	$V_{\text{TEMP}} > V_{\text{COLD}}$	Charge Suspended	Charge Suspended

Recharge

After a charge cycle has terminated, if the charge current rises above 30% of the constant charge current, or battery voltage falls below 4.085V, a new charge cycle will begin automatically.

Constant-Current/Constant-Voltage/Constant-Temperature

The CN3142 use a unique architecture to charge a battery in a constant-current, constant-voltage, constant temperature fashion as shown in Figure 2. Amplifiers Iamp, Vamp, and Tamp are used in three separate feedback loops to force the charger into constant-current, constant-voltage, or constant-temperature mode, respectively. In constant current mode the charge current delivered to the battery equal to $502V/R_{\text{ISET}}$. If the power dissipation of the CN3142 results in the junction temperature approaching 132°C, the amplifier Tamp will begin decreasing the charge current to limit the die temperature to approximately 132°C. As the battery voltage rises, the CN3142 either returns to constant-current mode or it enters constant voltage mode straight from constant-temperature mode.

Over Charge Current Protection

During normal operation, the charge current should be regulated to the value set by the resistor at ISET pin. However, if a short circuit or a misuse of abnormally small resistance occurs on ISET pin, the charge current may rise to unintended level. If the charge current exceeds over charge current threshold I_{OC}, the CN3142 is turned off after a deglitch time of t_{OCP_DGL}.

The CN3142 remains latched off, and will not restart operation until the input supply is removed and re-applied.

CONSONANCE

Open-Drain Status Outputs

The CN3142 have an open-drain status outputs $\overline{\text{CHRG}}$. $\overline{\text{CHRG}}$ pin outputs a pulse of 2Hz frequency in charging status, and is pulled low when the charger is in termination status; in other cases $\overline{\text{CHRG}}$ pin becomes high impedance.

If battery temperature is in hot and cold range, $\overline{\text{CHRG}}$ pin becomes high impedance.

If CN3142 is in sleep mode, $\overline{\text{CHRG}}$ pin also becomes high impedance.

$\overline{\text{CHRG}}$ pin should be tied to ground if not used.

VIN Bypass Capacitor

Many types of capacitors can be used for input bypassing(C1 in Figure 1), Generally, a 1uF to 10uF (Case:0805) ceramic capacitor, placed in close proximity to VIN and GND pins, works well. In some applications depending on the input power supply characteristics, cable length or input power supply being short-circuit , it may be necessary to increase the capacitor's value.

If the ceramic capacitor is used as the input supply bypassing purpose, a voltage spike may be created when the input voltage is applied to the CN3142 via a cable. In extreme cases, the circuit shown in Figure 5 should be considered to use to prevent the CN3142 from being damaged by the voltage spike.

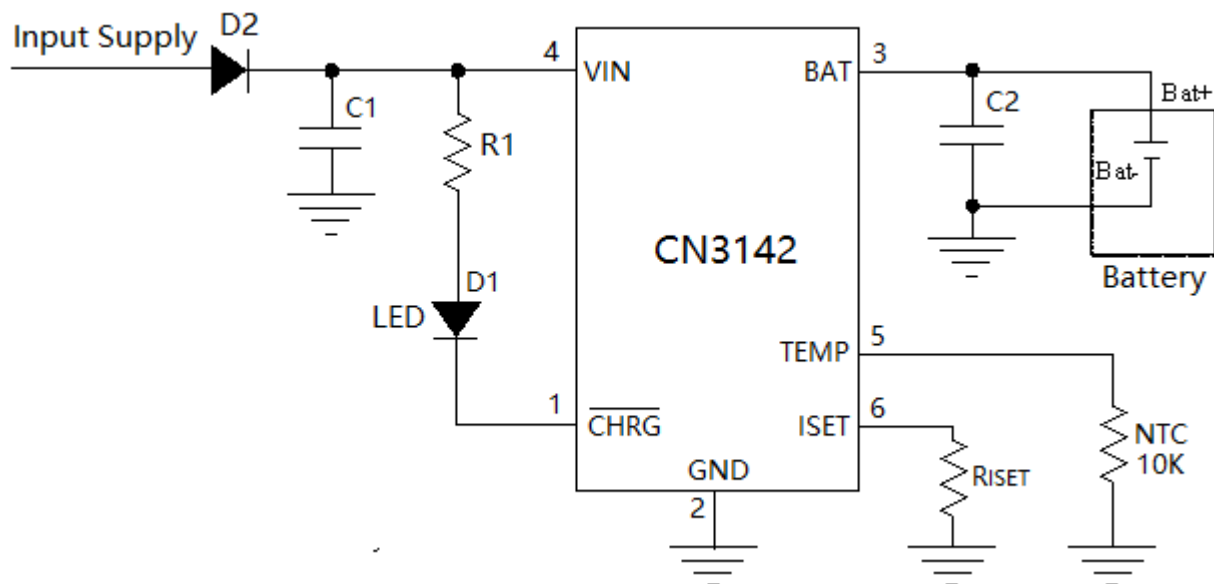

Figure 5 Adding Diode D2 to Suppress Voltage Spike

Stability

A capacitor from BAT pin to GND is required to stabilize the feedback loop, generally the feedback loop is stable with an 1uF to 22uF ceramic capacitor. If electrolytic capacitor is used, the capacitance can be as high as 100uF.

In constant current mode, the stability is also affected by the impedance at the ISET pin. With no additional capacitance on the ISET pin, the loop is stable with current set resistors values as high as 168K Ω . However, additional capacitance on ISET pin reduces the maximum allowed current set resistor, there should not be a capacitance between ISET pin and GND.

Board Layout Considerations

1. R_{ISET} at ISET pin should be as close to CN3142 as possible, also the parasitic capacitance at ISET pin should be kept as small as possible.
2. The capacitor at VIN pin and BAT pin should be as close to CN3142 as possible.

CONSONANCE

3. During charging, CN3142's temperature may be high, the NTC thermistor should be placed far enough to CN3142 so that the thermistor can reflect the battery's temperature correctly.
4. It is very important to use a good thermal PC board layout to maximize charging current. The thermal path for the heat generated by the IC is from the die to the copper lead frame through the package lead (especially the ground lead) to the PC board copper, the PC board copper is the heat sink. The footprint copper pads should be as wide as possible and expand out to larger copper areas to spread and dissipate the heat to the surrounding ambient. Feedthrough vias to inner or backside copper layers are also useful in improving the overall thermal performance of the charger. Other heat sources on the board, not related to the charger, must also be considered when designing a PC board layout because they will affect overall temperature rise and the maximum charge current.

CONSONANCE

Package Information (SOT23-6)

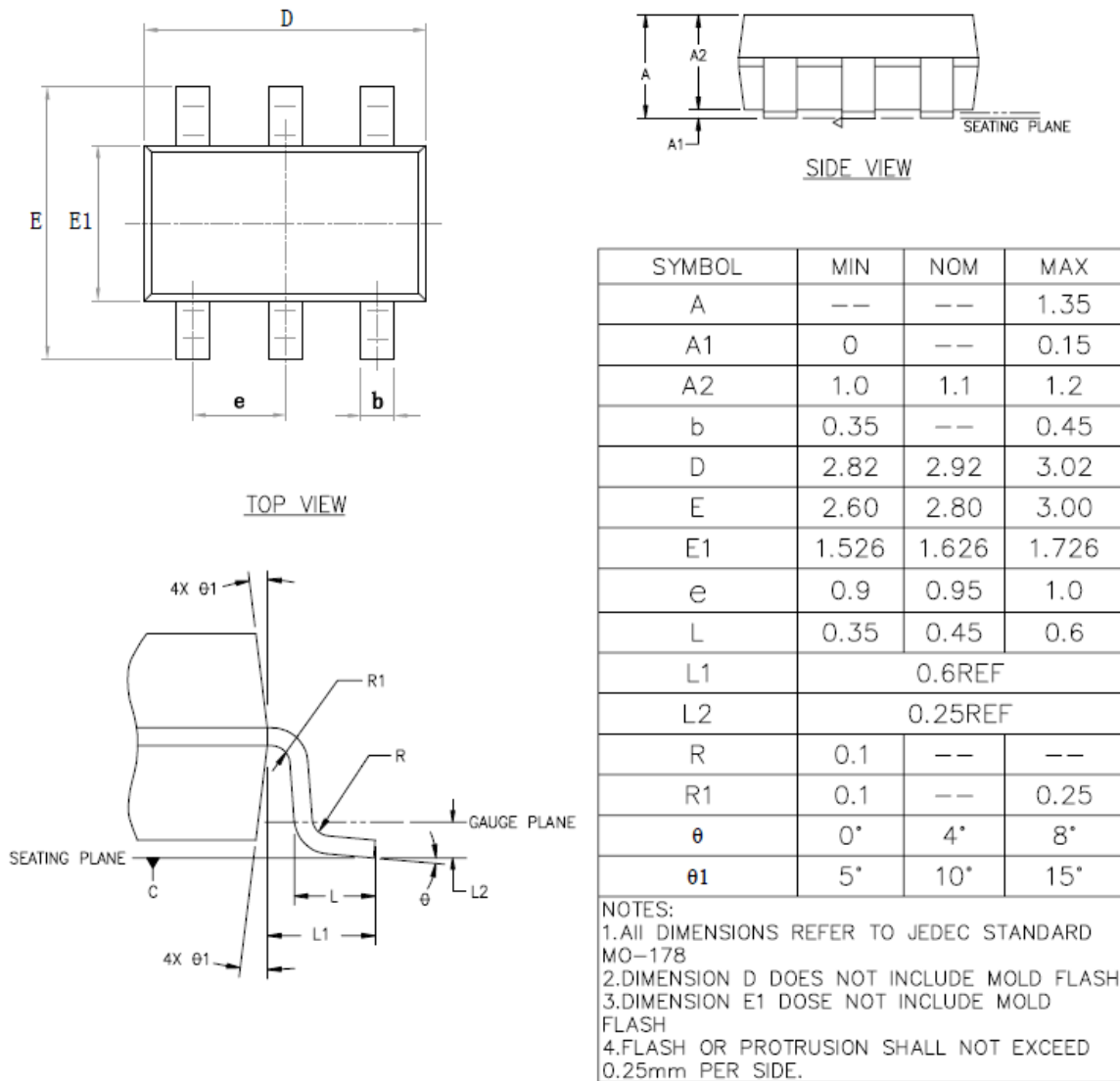

Important Notice

Consonance Electronics reserves the right to make corrections, modifications, enhancements, improvements and other changes to its products and specifications at any time without notice.

Consonance Electronics assumes no liability for applications assistance or technique support or the use of any circuitry described in the specification during customer product designing and developing. Customers are solely responsible for their products and applications using Consonance Electronics products. Customer should provide adequate design, test and operating safeguard based on its products' operating environment and conditions.